

4

3

2

1

THIS DRAWING IS UNPUBLISHED. RELEASED FOR PUBLICATION, 19 .

© COPYRIGHT 19 BY AMP INCORPORATED. ALL RIGHTS RESERVED.

LOC		DIST		REVISIONS			
P	LTR	DESCRIPTION		DATE	DWN	APVD	
G	14	G		ADDED -21 PER 063A-0273-00	22MAY00	JR MS	

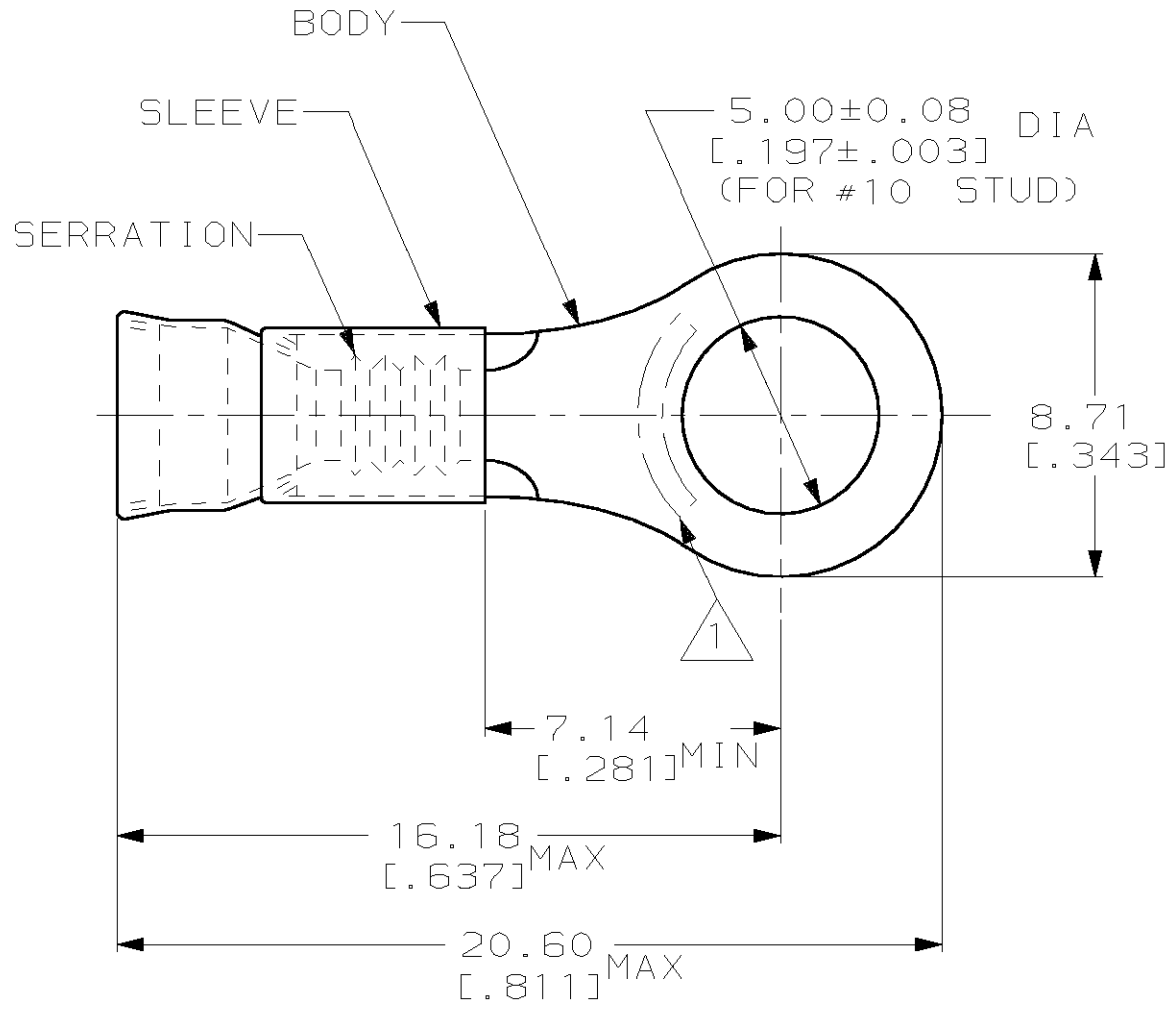

- 1. STAMP AMP 16-14*APPROX AS SHOWN
- 2. WIRE INSUL DIA, 3.05-4.32 [.120-.170]
- 3. TONGUE MATL THK, 0.79±0.05 [.031±.002]
- 4. PRELIMINARY - NOT FOR PRODUCTION

QTY	PACKAGE TYPE	PART NO
5000	ON TAPE, REEL	2-322375-1
1000	LOOSE PIECE	322375

AMP INCORPORATED CUSTOMER SERVICE SYSTEM		MAX RECOMMENDED OPERATING TEMPERATURE: 343°C [650°F]	THIS DRAWING IS A CONTROLLED DOCUMENT FOR AMP INCORPORATED. IT IS SUBJECT TO CHANGE AND THE CONTROLLING ENGINEERING ORGANIZATION SHOULD BE CONTACTED FOR THE LATEST REVISION.		DWN L OLMEDA 100CT94	AMP AMP Incorporated Harrisburg, PA 17105-3608		
FOR ADDITIONAL PRODUCT INFORMATION OR COPIES OF DRAWINGS AND TECHNICAL DOCUMENTS	PRODUCT INFORMATION CENTER 1-800-522-6752	VOLTAGE RATING: -	DIMENSIONS: mm [in]	TOLERANCES UNLESS OTHERWISE SPECIFIED: 0 PLC ±- 1 PLC ±- 2 PLC ±0.20 [.008] 3 PLC ±- 4 PLC ±- ANGLES ±-	CHK M ELLIS 100CT94		NAME S BORTNER 100CT94	
FOR APPLICATION TOOLING INFORMATION	TOOLING ASSISTANCE CENTER 1-800-722-1111	CIRCULAR MIL AREA: 1.04mm² -2.62mm² [2050-5180]	MATERIAL BODY, CU PER ASTM B152 SLEEVE, NI SIL PER ASTM B122		FINISH BODY, NP, QQ-N-290	PRODUCT SPEC -	APPLICATION SPEC -	
FOR ORDER ENTRY	1-800-526-5142	STRANDED WIRE	CUSTOMER DRAWING		WEIGHT -	SIZE A3	CAGE CODE 00779	DRAWING NO C-322375
						SCALE 6:1	SHEET 1 OF 1	REV G